

NTNU og SiT - Elg. 10

Oppstartsmøte detaljprosjekt

18.08.2020

Disposisjon

1. Prosjektet – konsept og hovedorganisering
2. Forprosjektmodell

Målet er å skape **gode undervisningsarealer, og arbeidslokaler**, men også et **viktig samlingspunkt** for sosial aktivitet; et **møtested for trening**, undervisning og sosialisering.

Bygget skal **pulsere** gjennom døgnet og **eksponere** det yrende, indre livet for omverdenen.

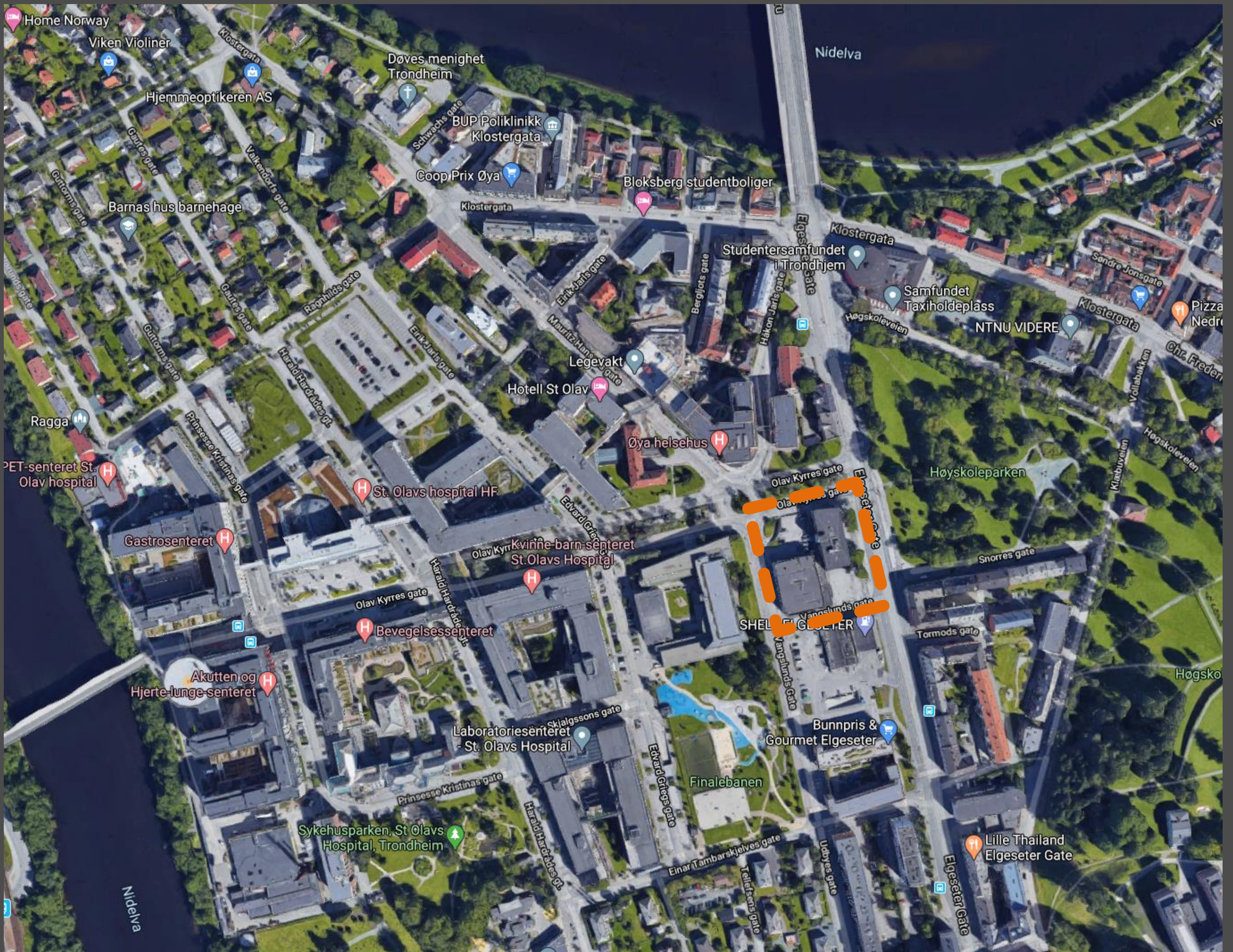

Konsept – plassering flerbrukshall

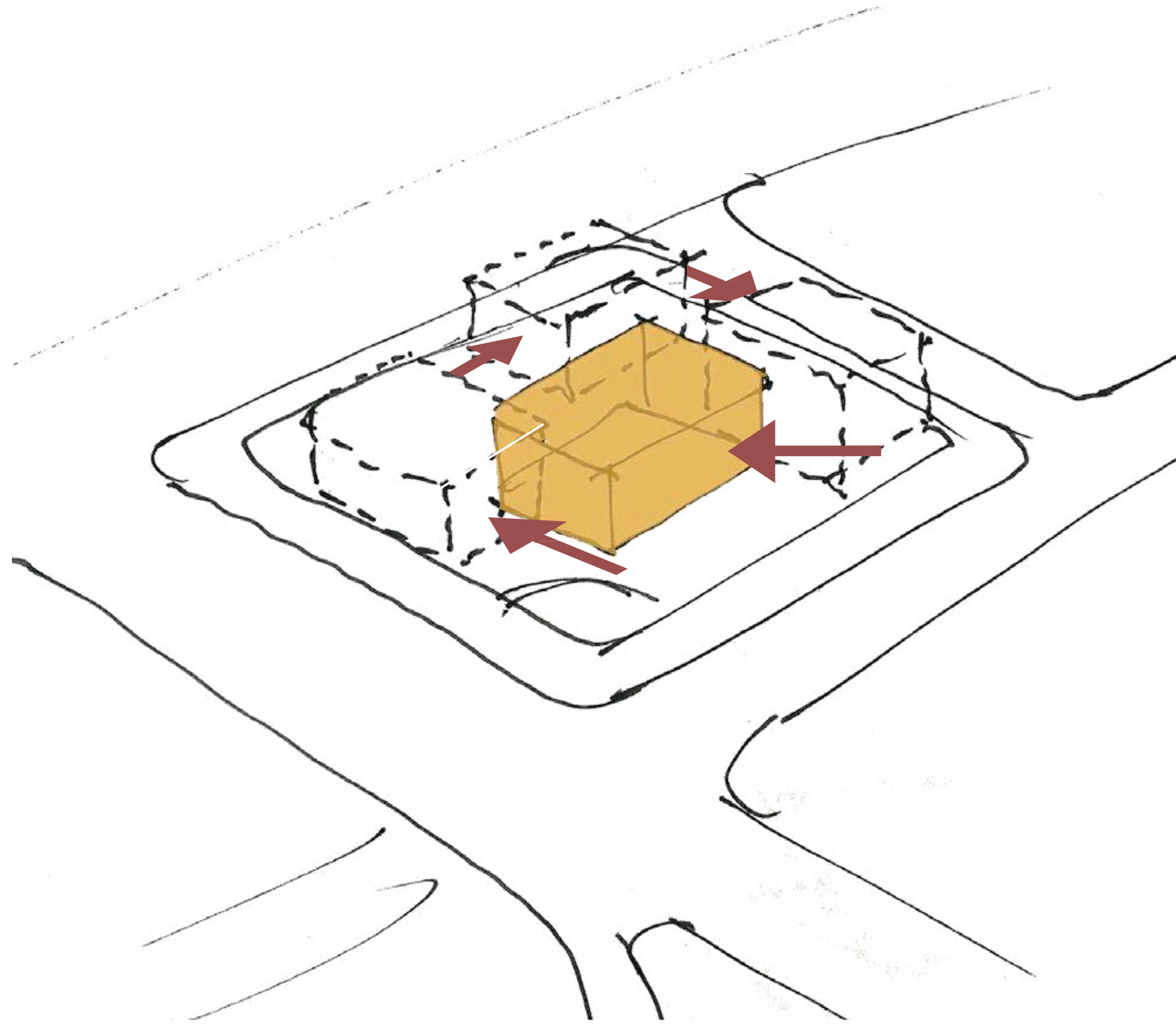

Konsept – plassering flerbrukshall

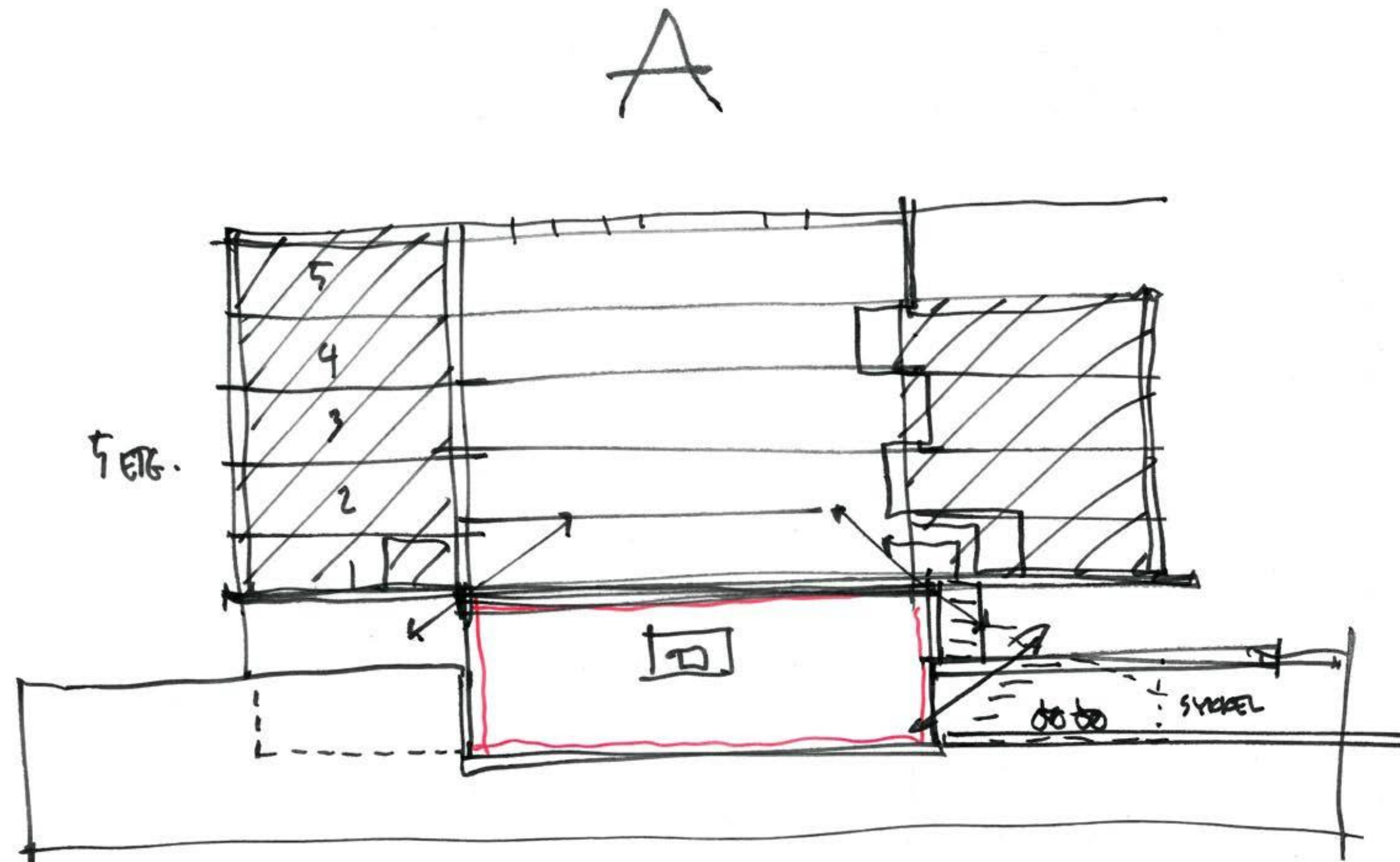

ALTERNATIVSVURDERING A

Hall på plan U1 og plan 1.

Gir atriumgulv en etasje opp og dårligere sammenheng mellom ute og inne.

Konsept – plassering flerbrukshall

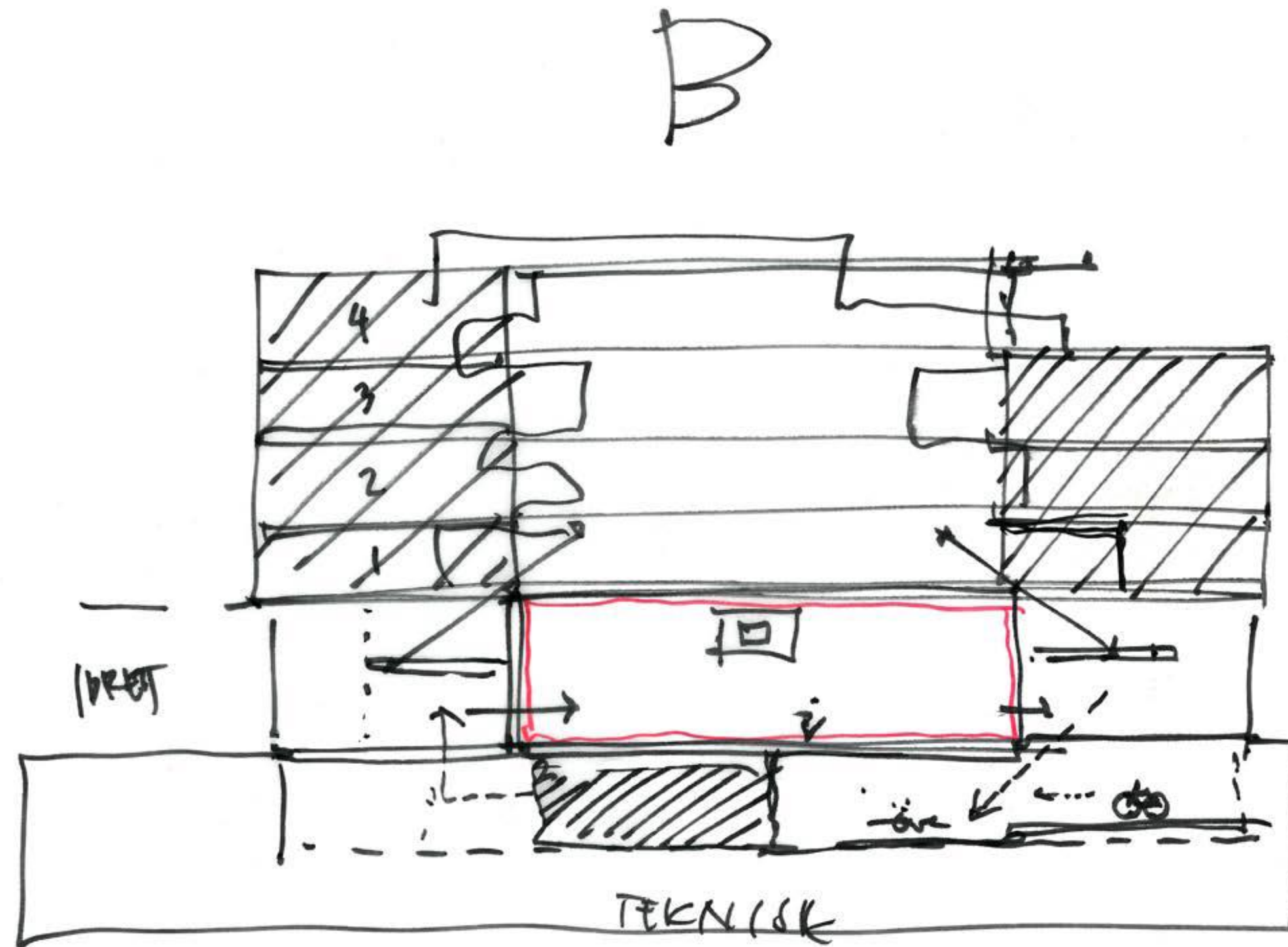

ALTERNATIVSVURDERING B

Hall på plan 1 og plan 2.

Gir atriumgulv i 2. etasje og gir svært dårlig sammenheng inne og ute og til fellesfunksjoner

Konsept – plassering flerbrukshall

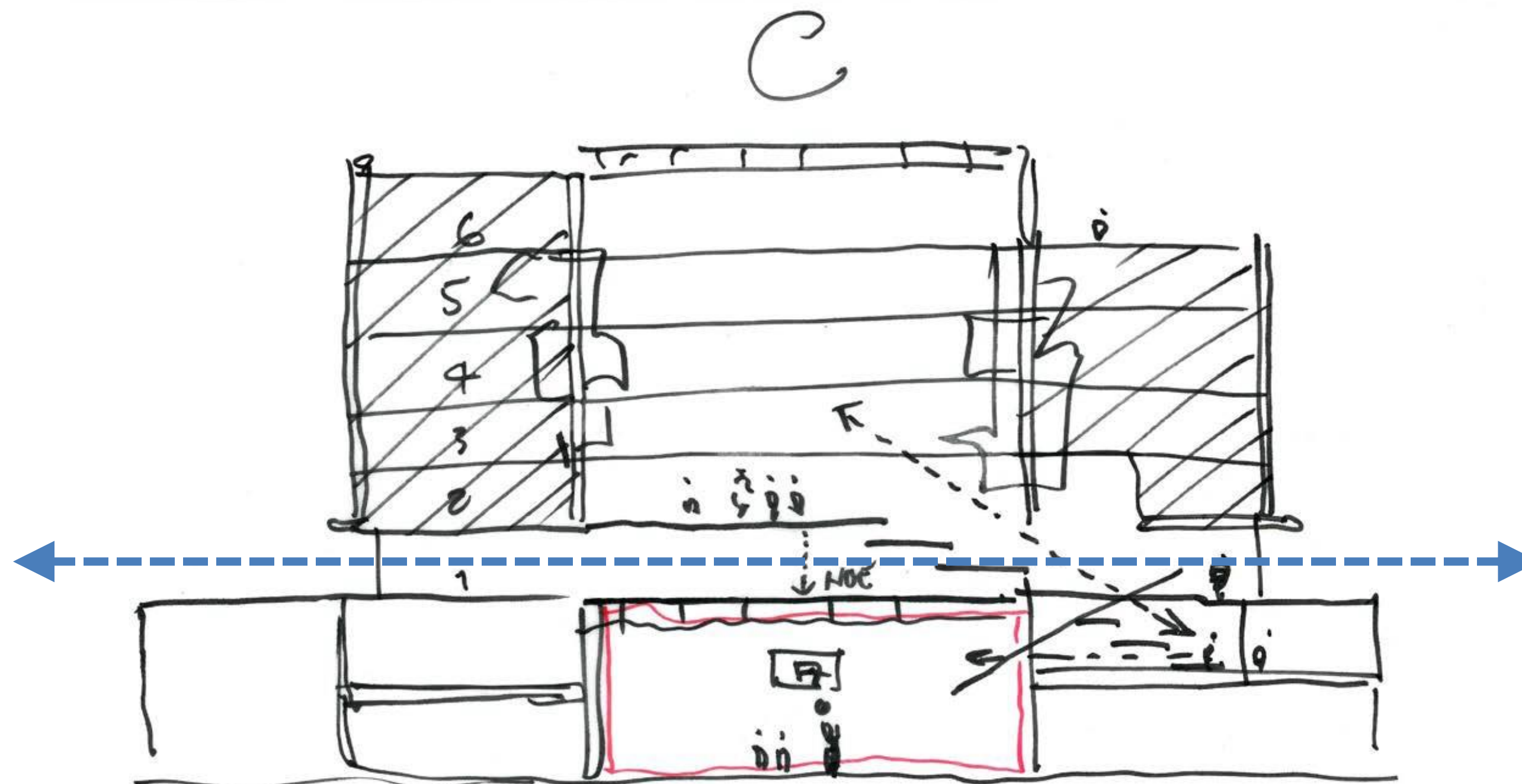

ALTERNATIVSVURDERING C

Hall på plan U2 og plan U1.

Gir atriumgulv på plan med omgivelsene og god kontakt og gjennomsyn.

Konsept - form

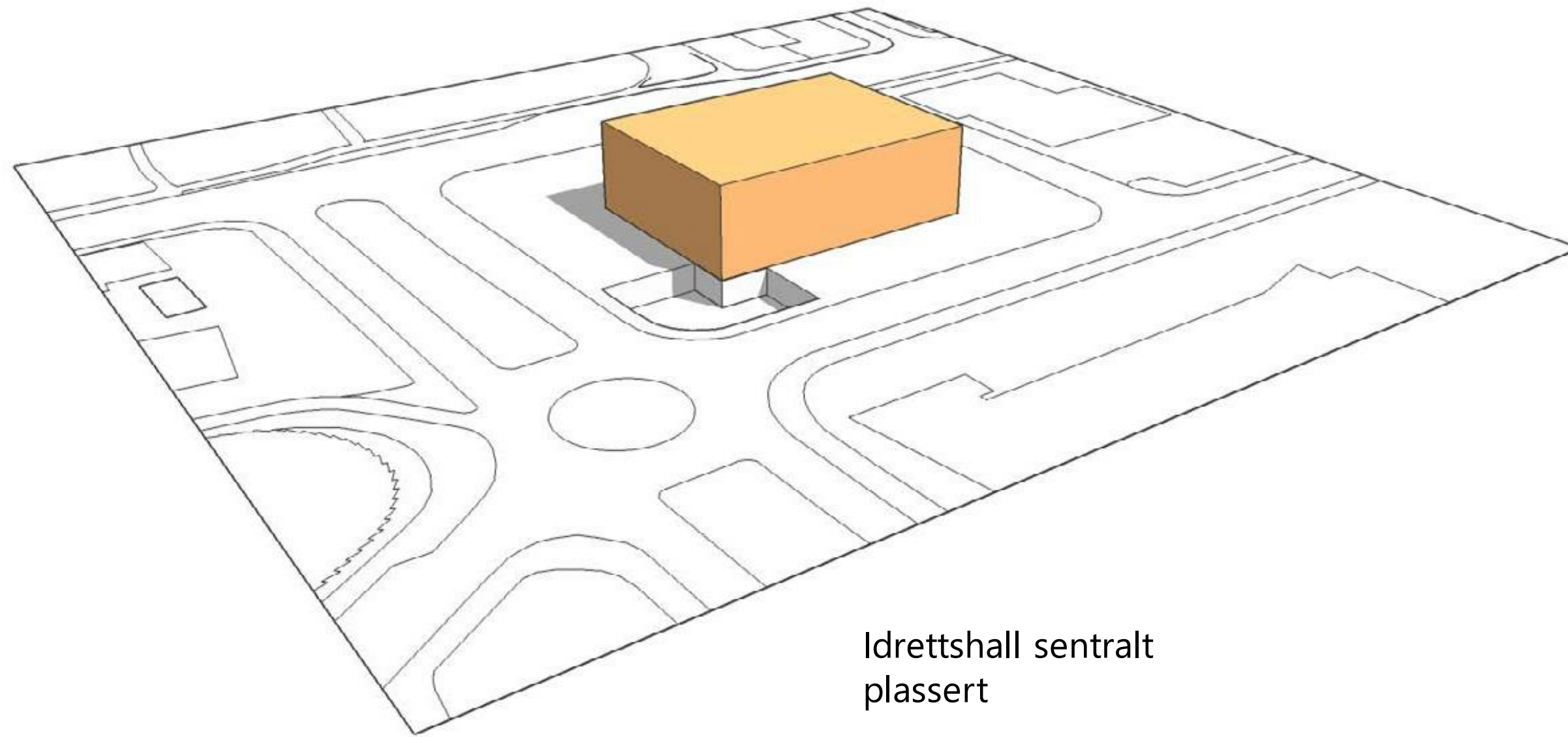

Idrettshall sentralt
plassert

Konsept - form

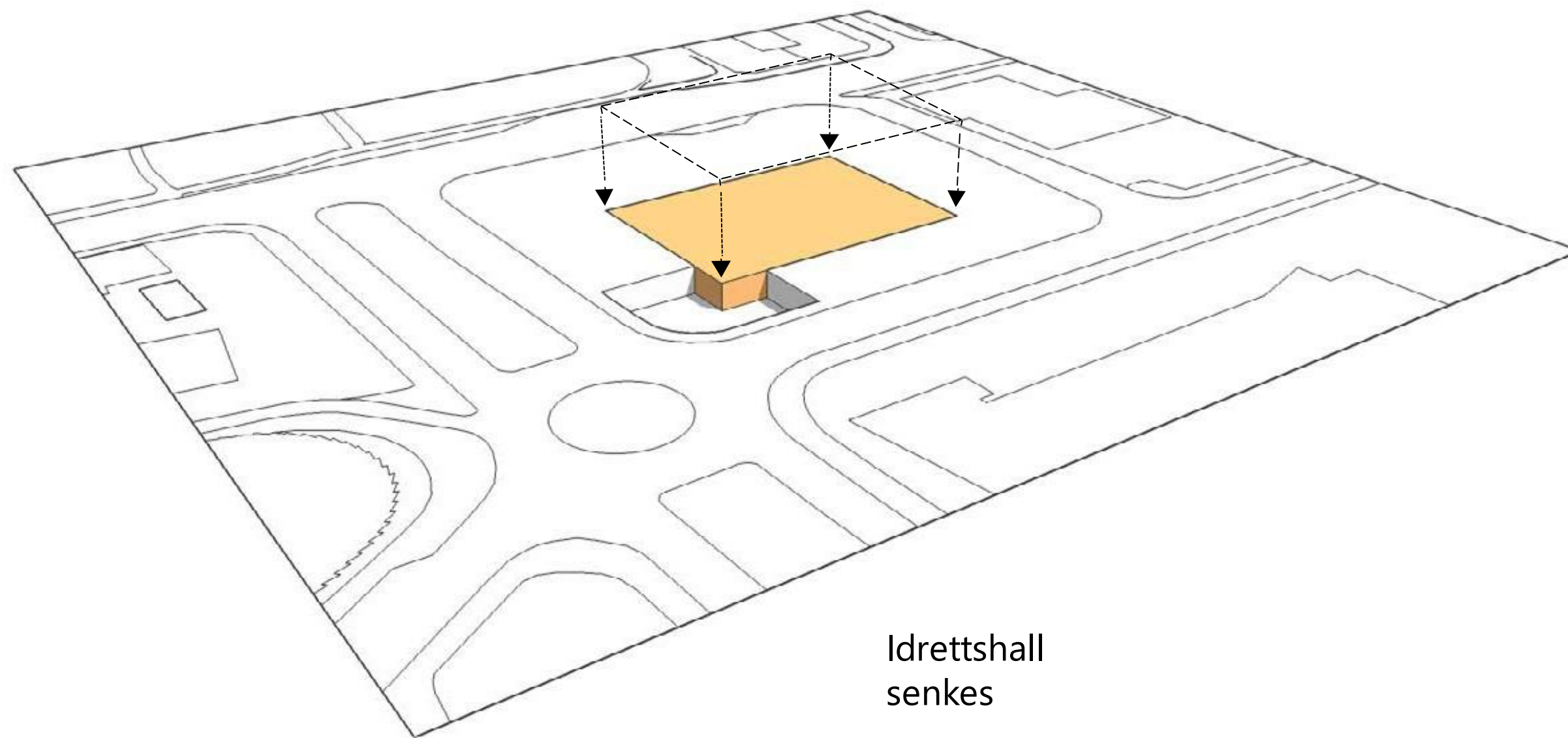

Konsept - form

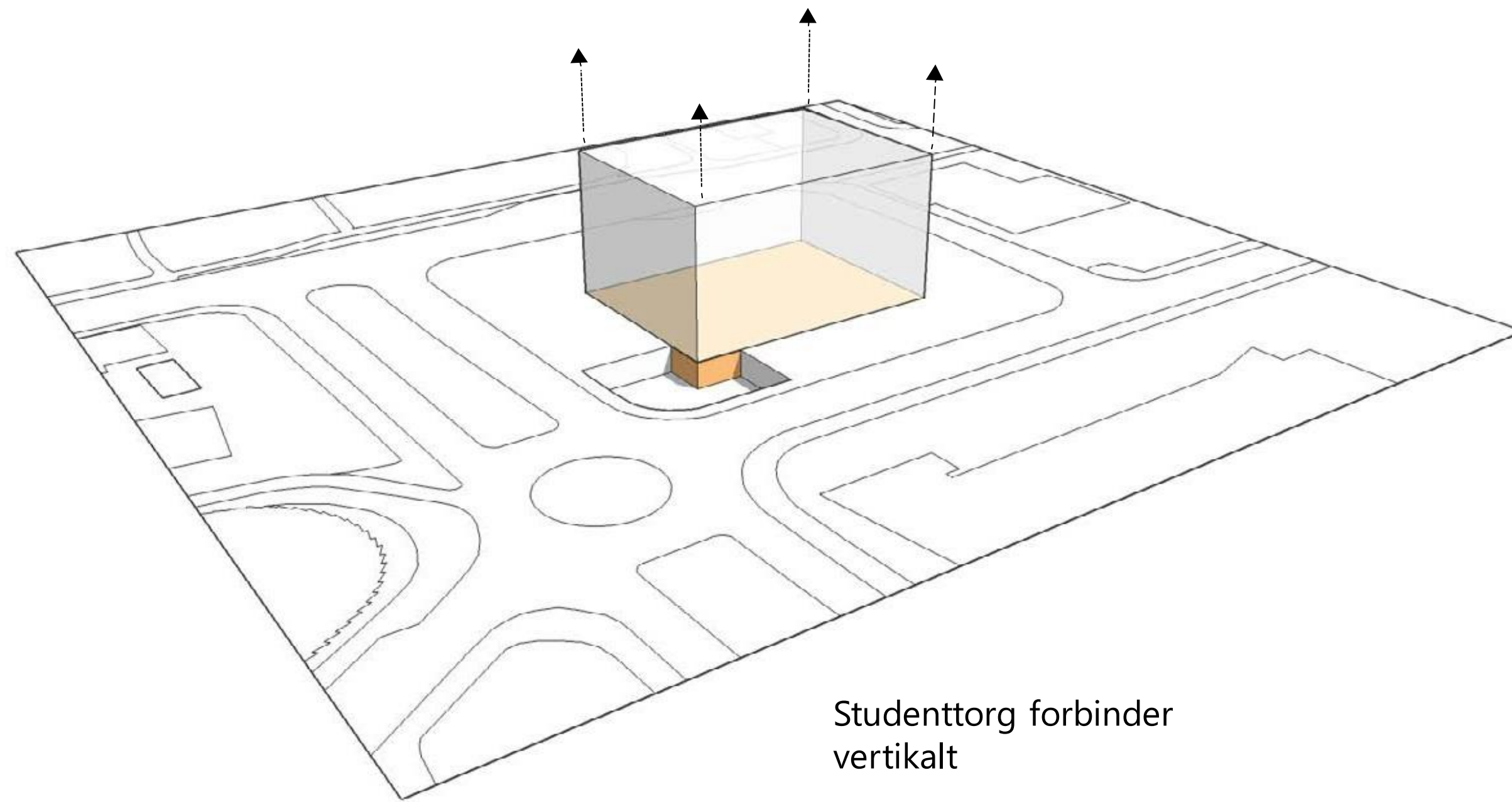

Studenttorg forbinder
vertikalt

Konsept - form

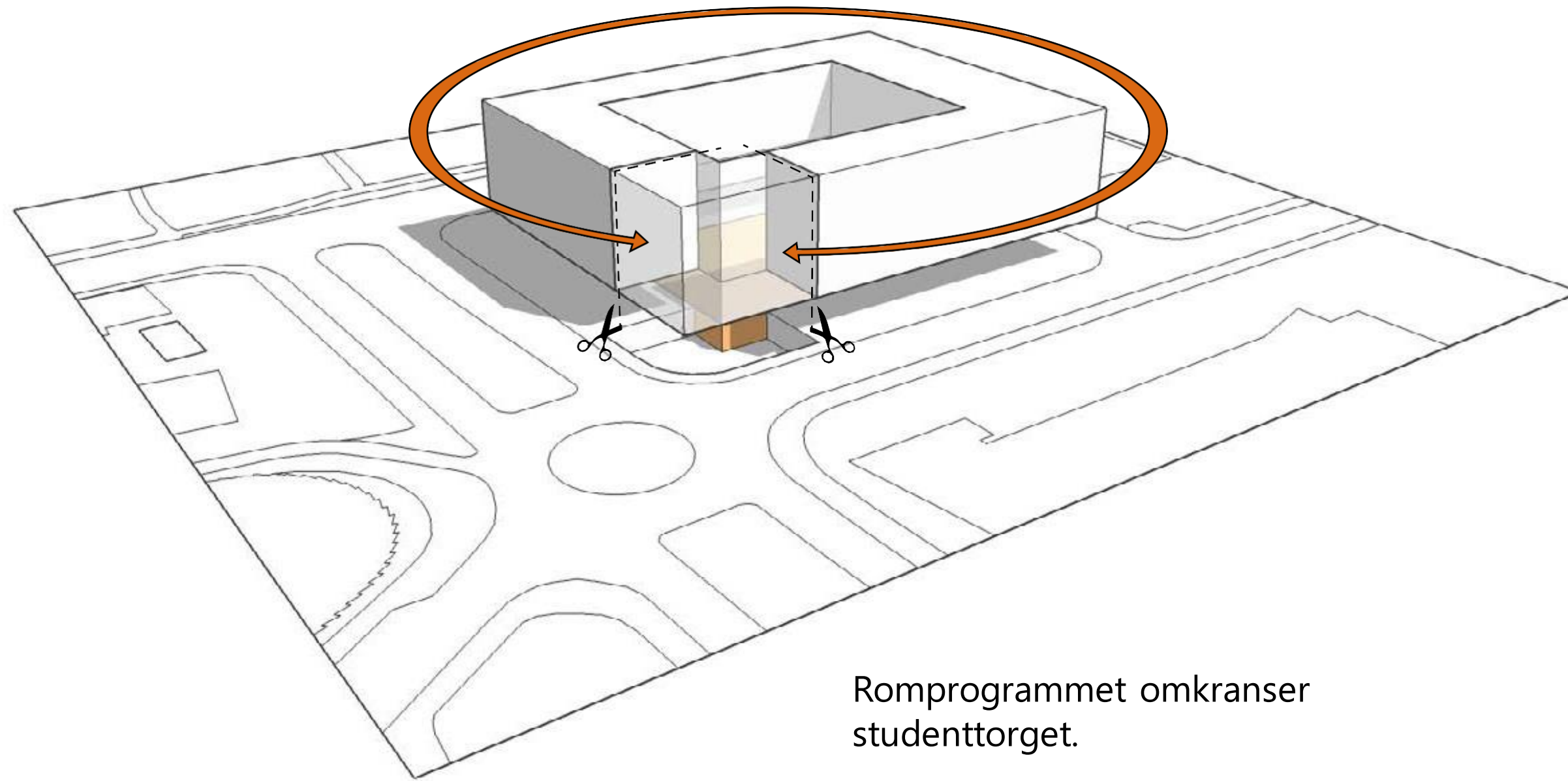

Romprogrammet omkranser studenttorget.

Konsept - form

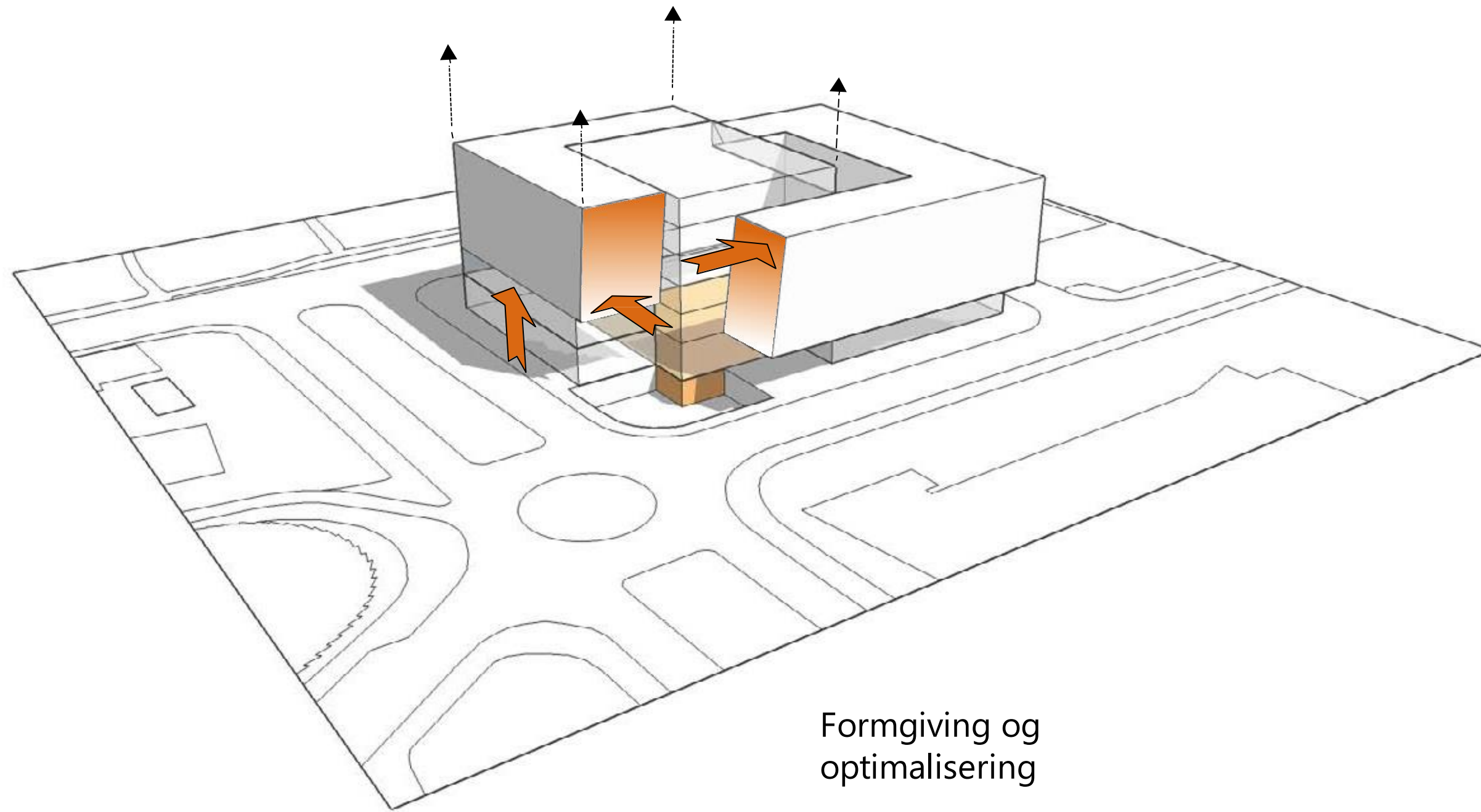

Formgiving og
optimalisering

Konzept - form

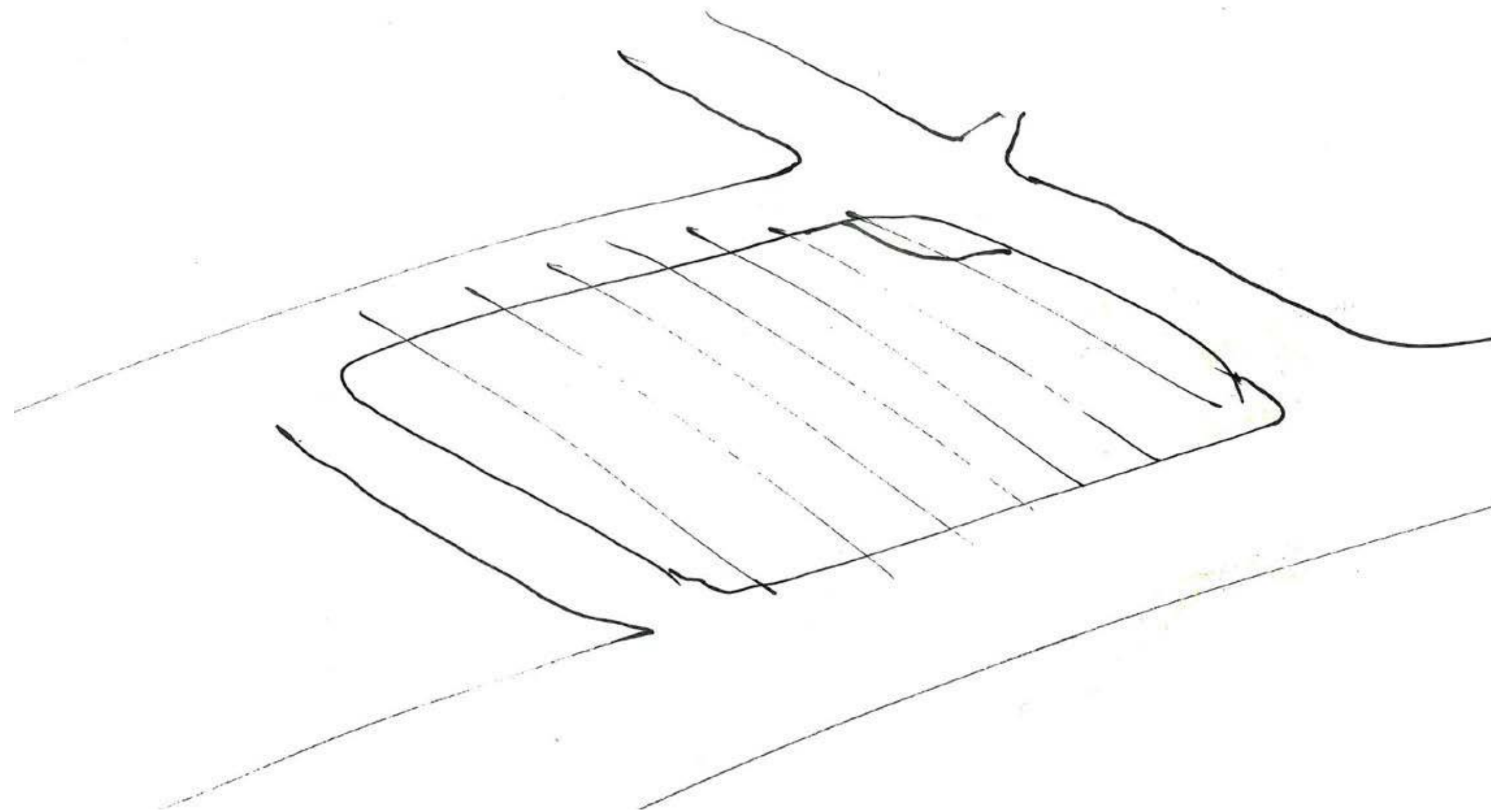

TORGET

Konzept - form

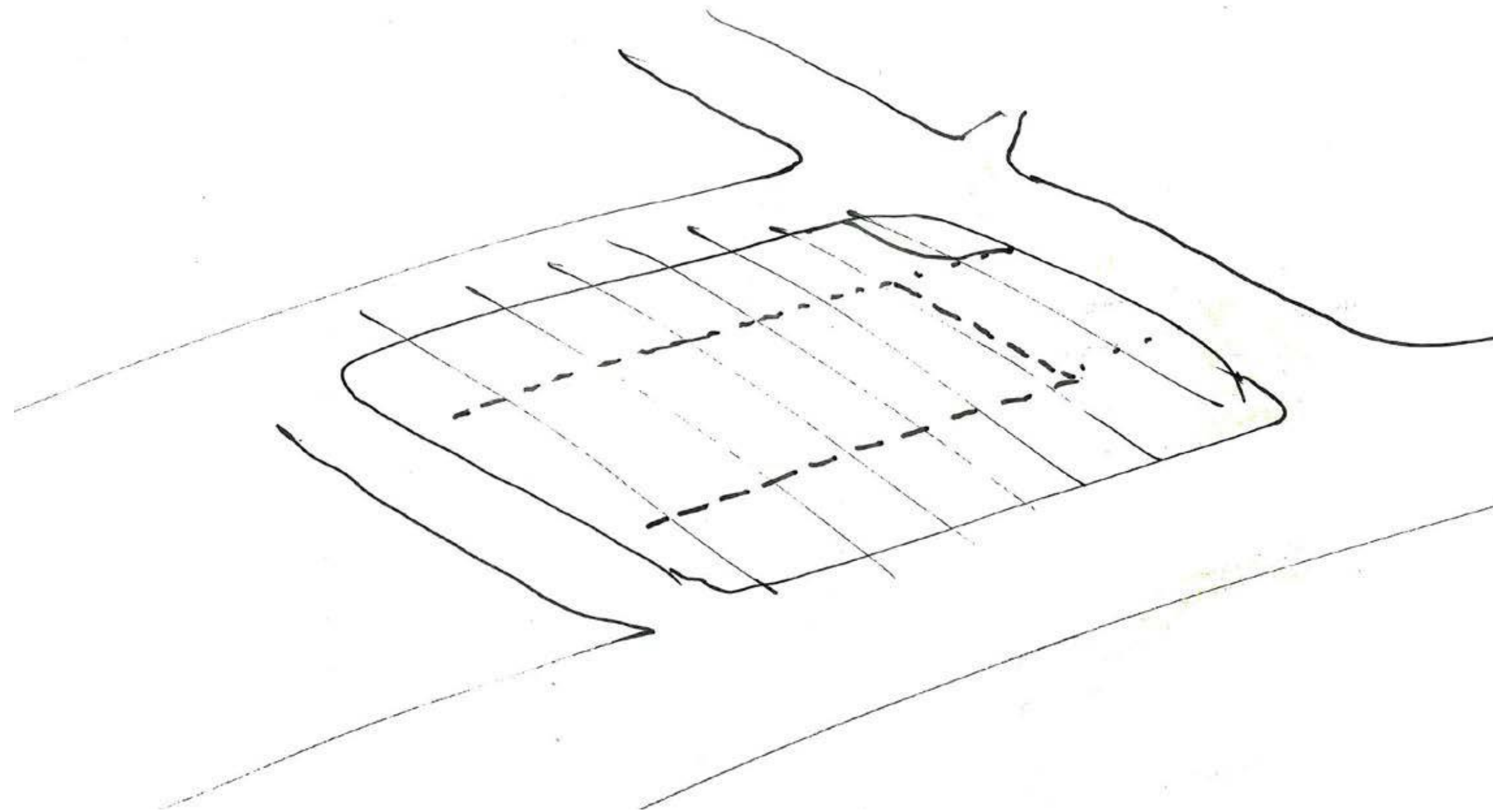

SENTRALT AREAL

Konsept - form

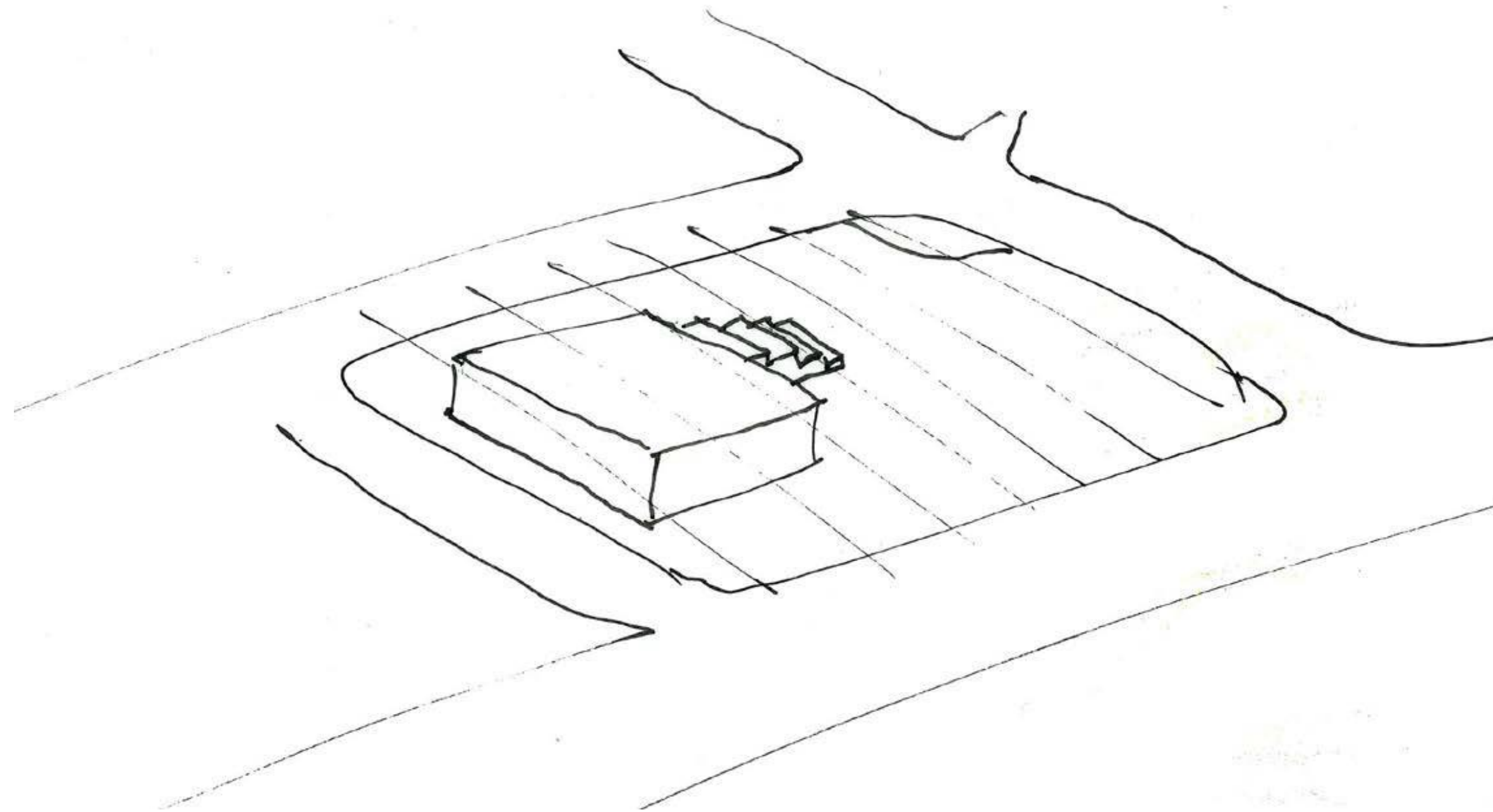

SOKKELEN

Konzept - form

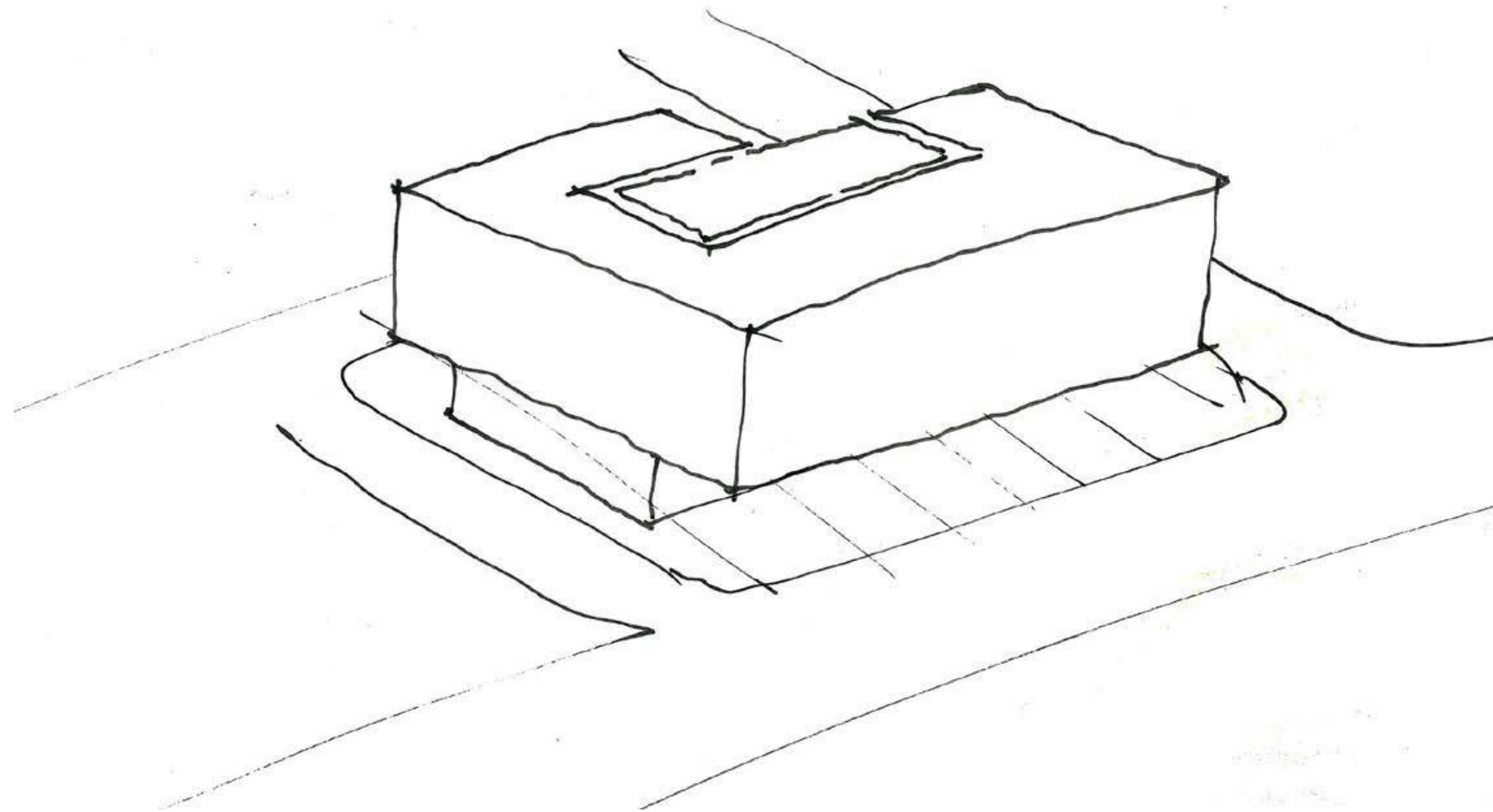

PROGRAMAREAL

Konsept - form

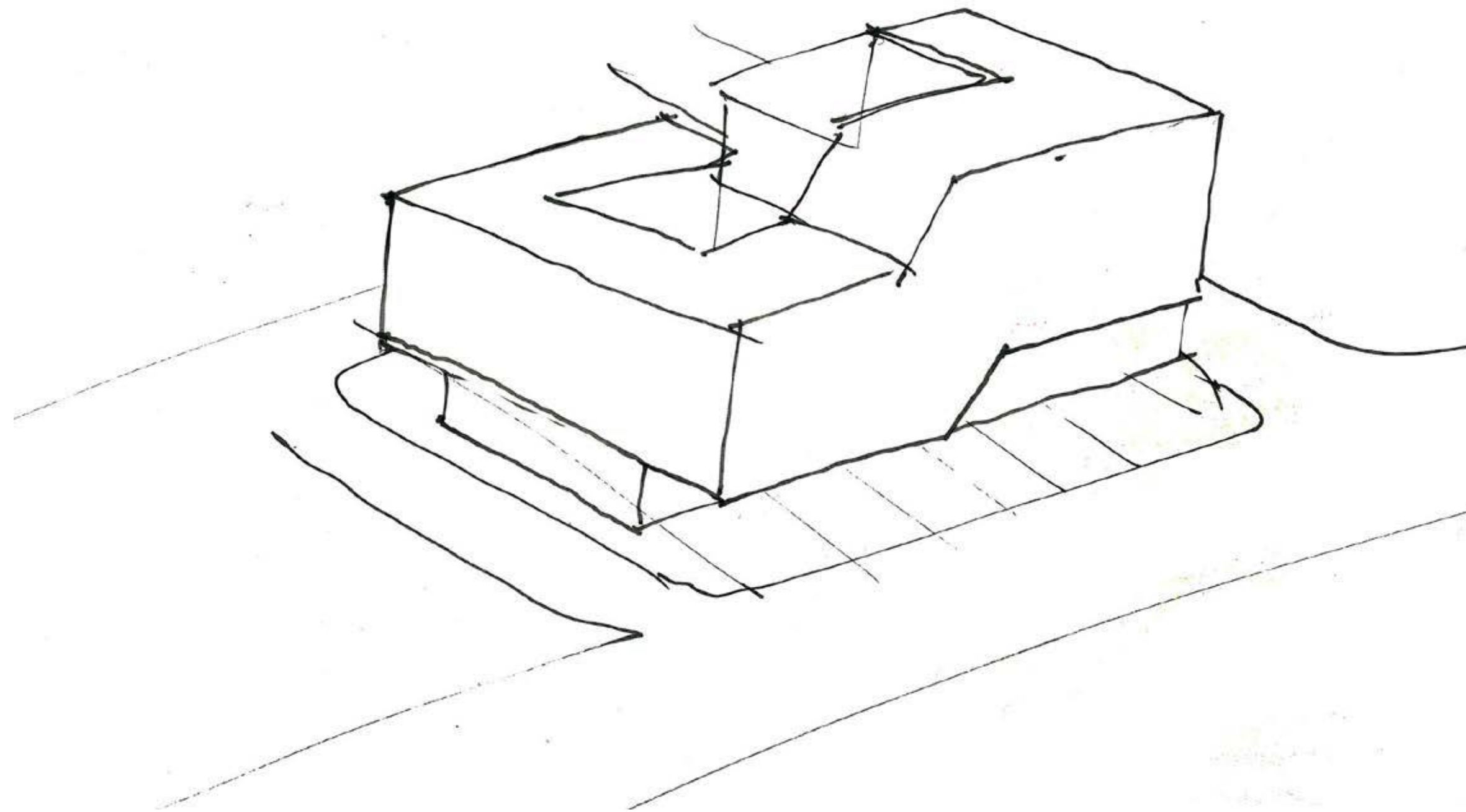

LØFTER HJØRNET

Konsept - form

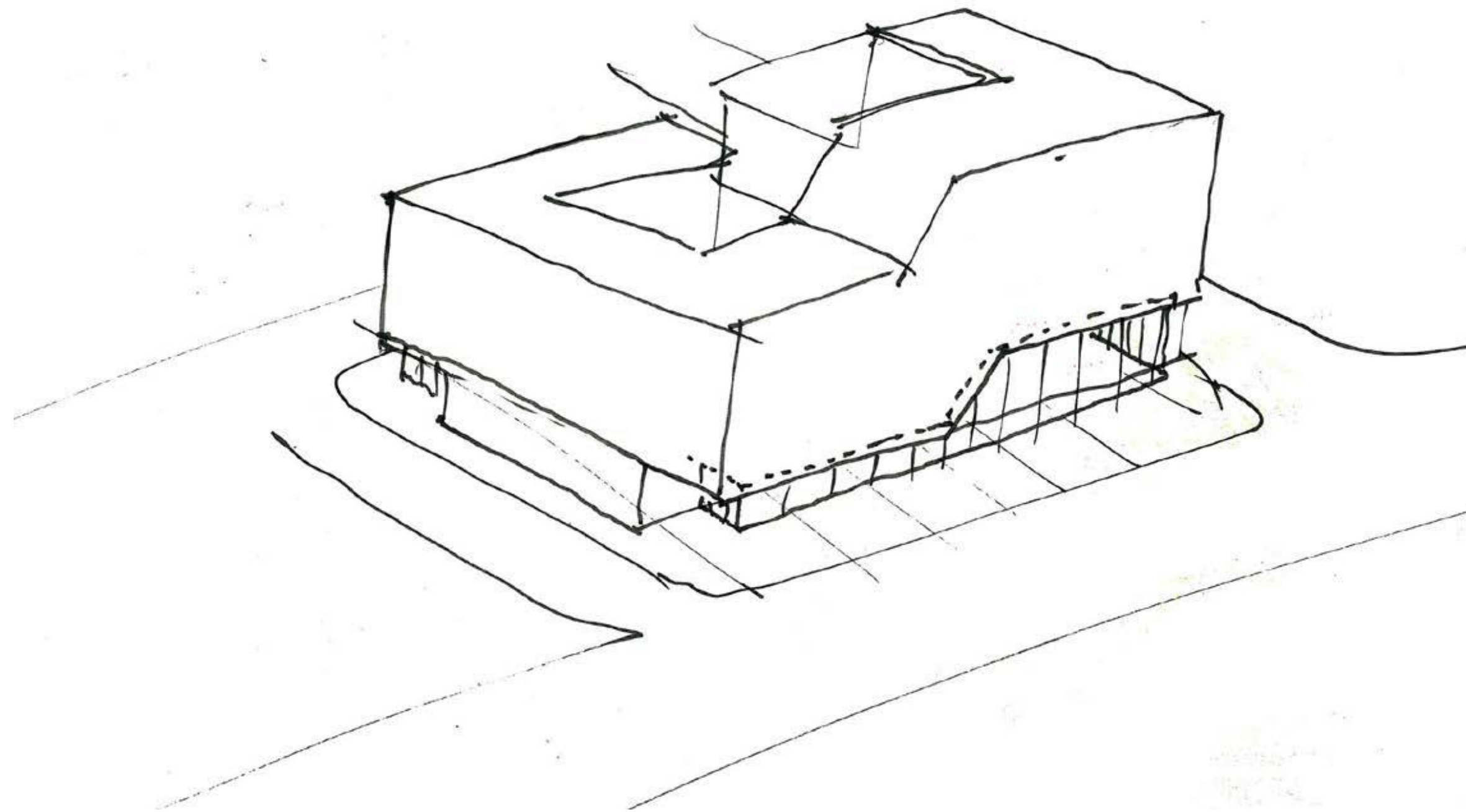

KLIMASKALL PLAN 1 OG 2

Vi har sett for oss et **myldrende studenttorg**
- personer på vei til undervisning, trening,
jobb, eller bare for en kopp kaffe eller en
salat der studenttorget er arenaen alle
krysser, og **der tilfeldige møter oppstår.**

Konsept – studenttorget og 'maurtua'

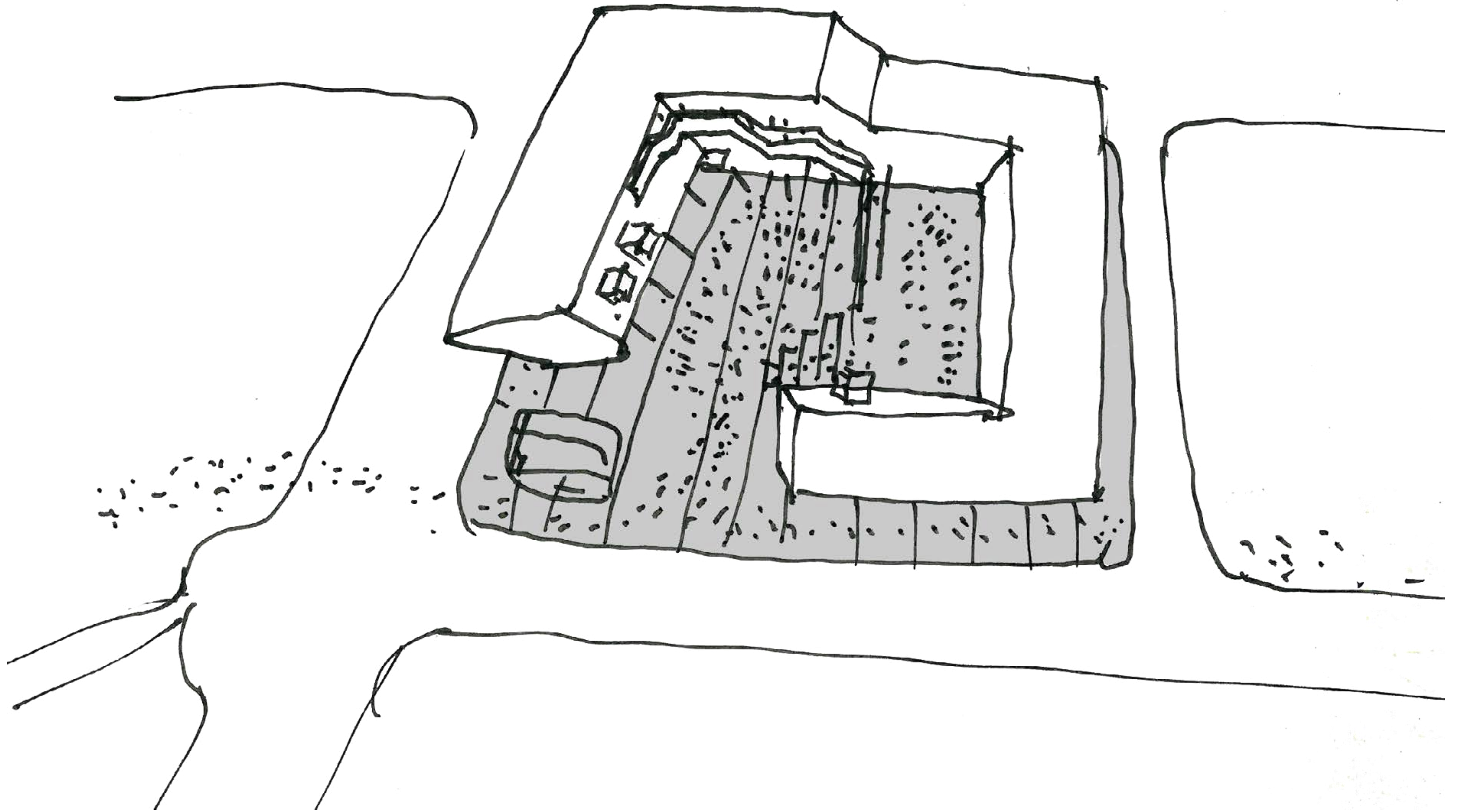

Konsept – husets hjerte

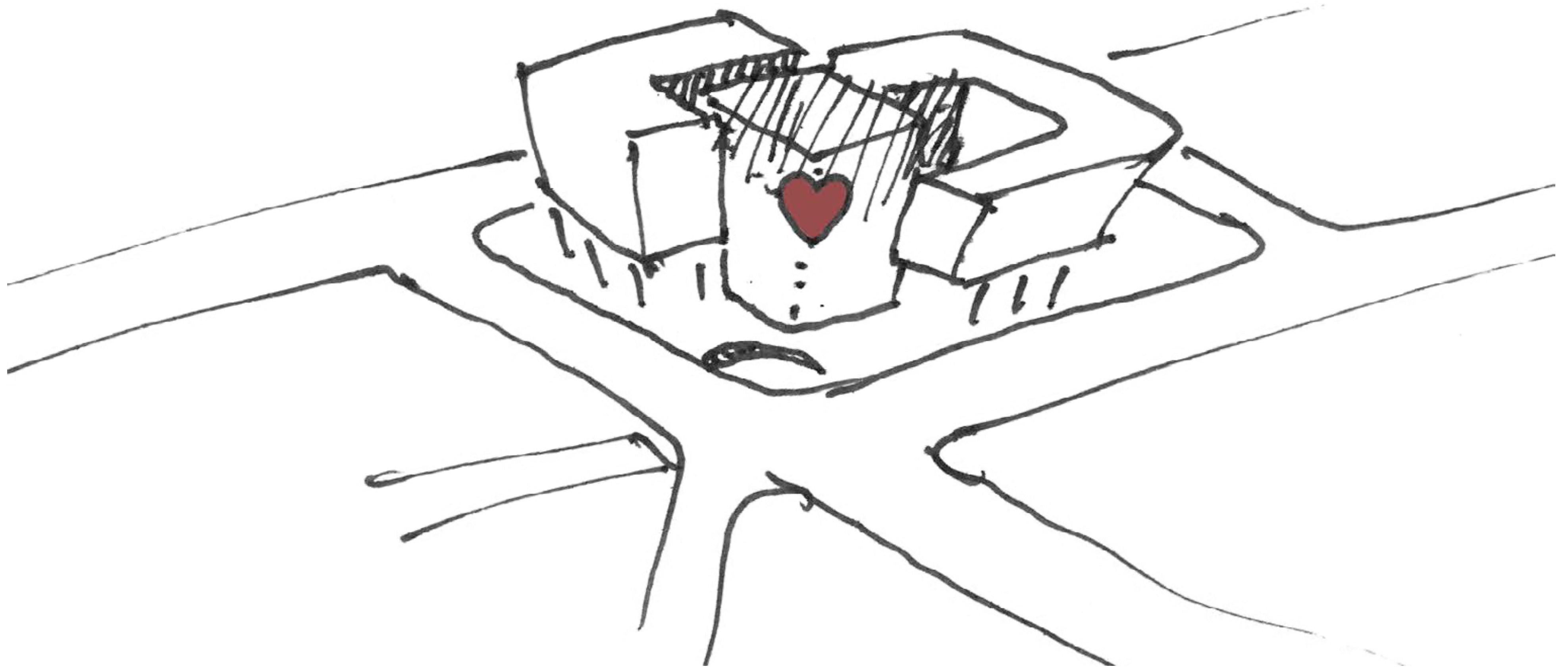

Konsept – Organisering - universell utforming

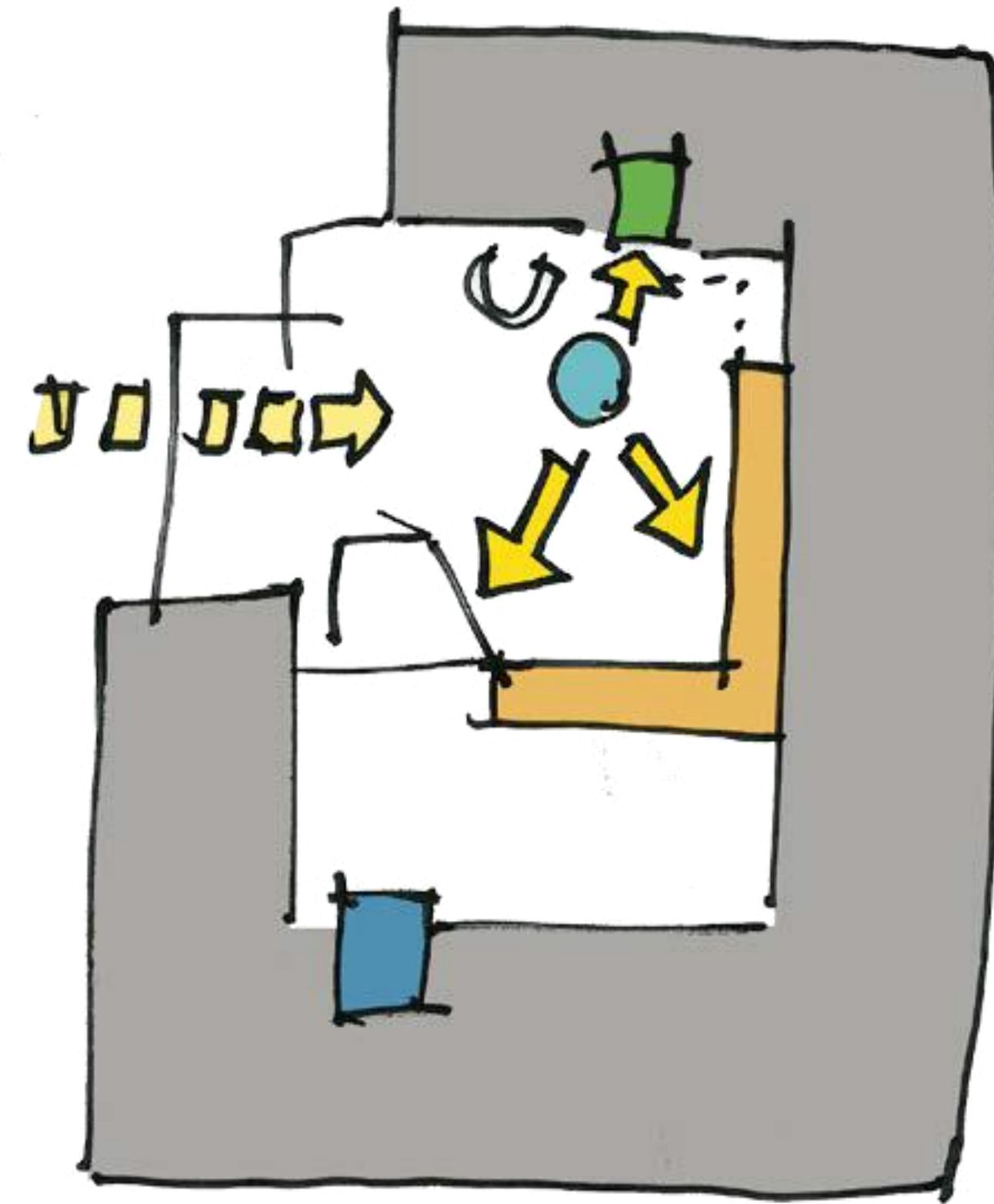
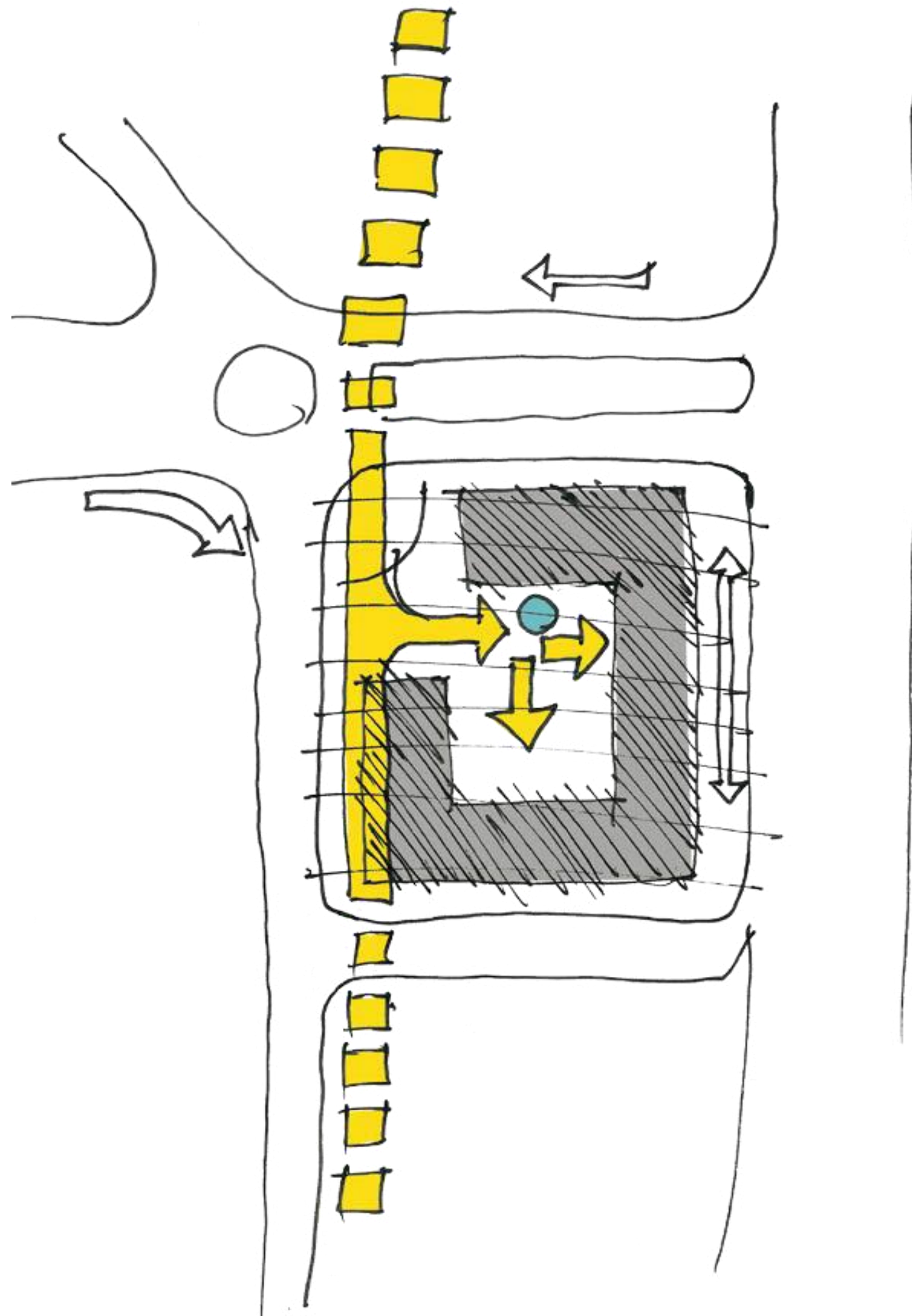

ÅPEN, OVERSIKTLIG STRUKTUR GJØR DET ENKELT Å ORIENTERE SEG

Konsept – Organisering - universell utforming

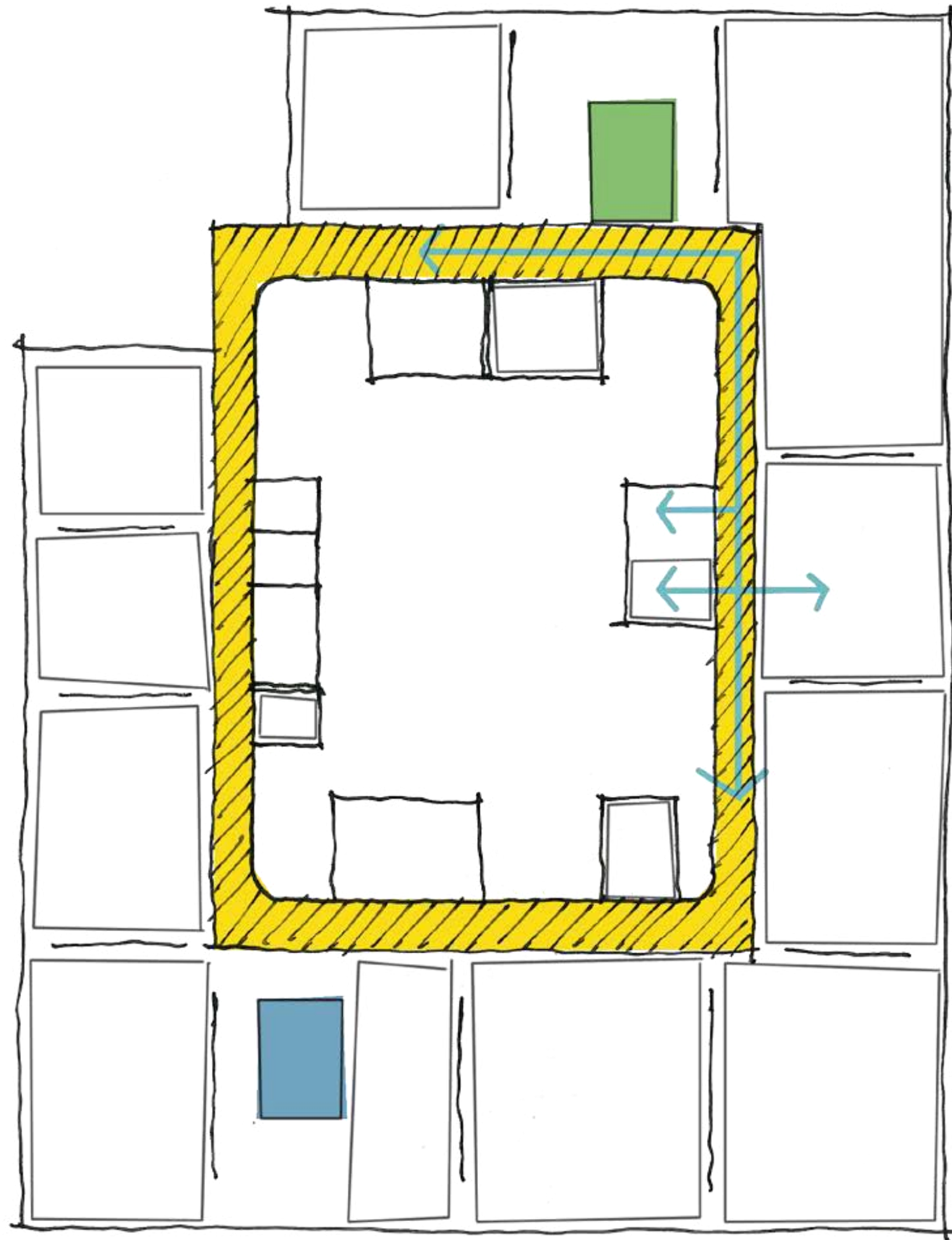

HORISONTAL KOMMUNIKASJON NATURLIGE LEDELINJER

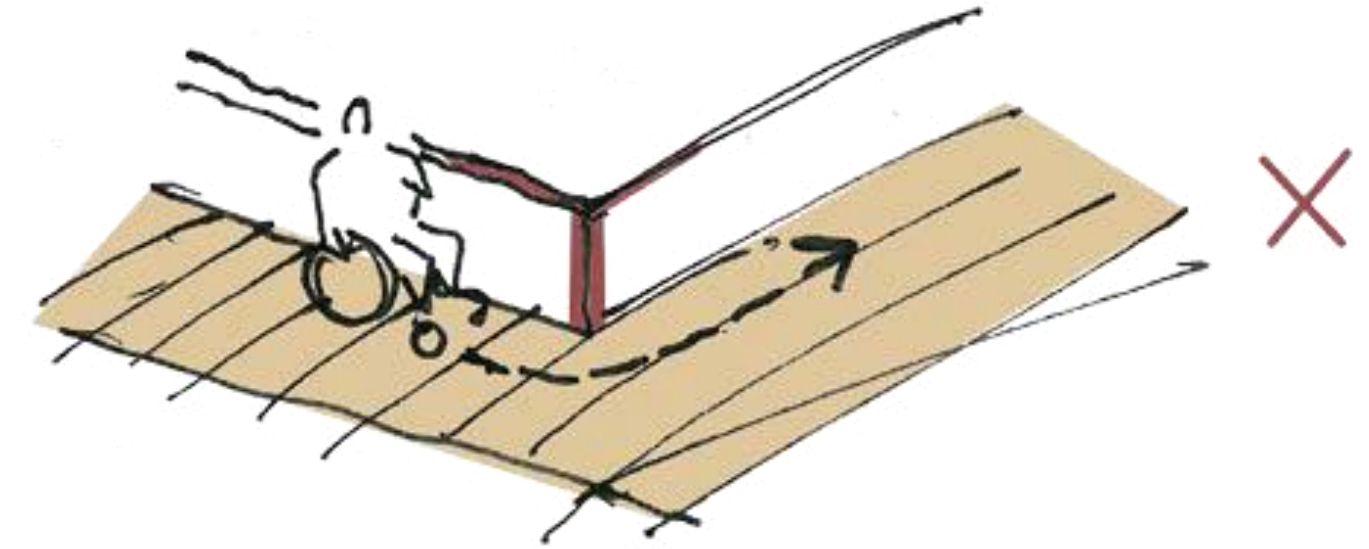

BEVEGELSE I GANGSØNE

Konsept – Universell utforming

ENKEL
ORIENTERING

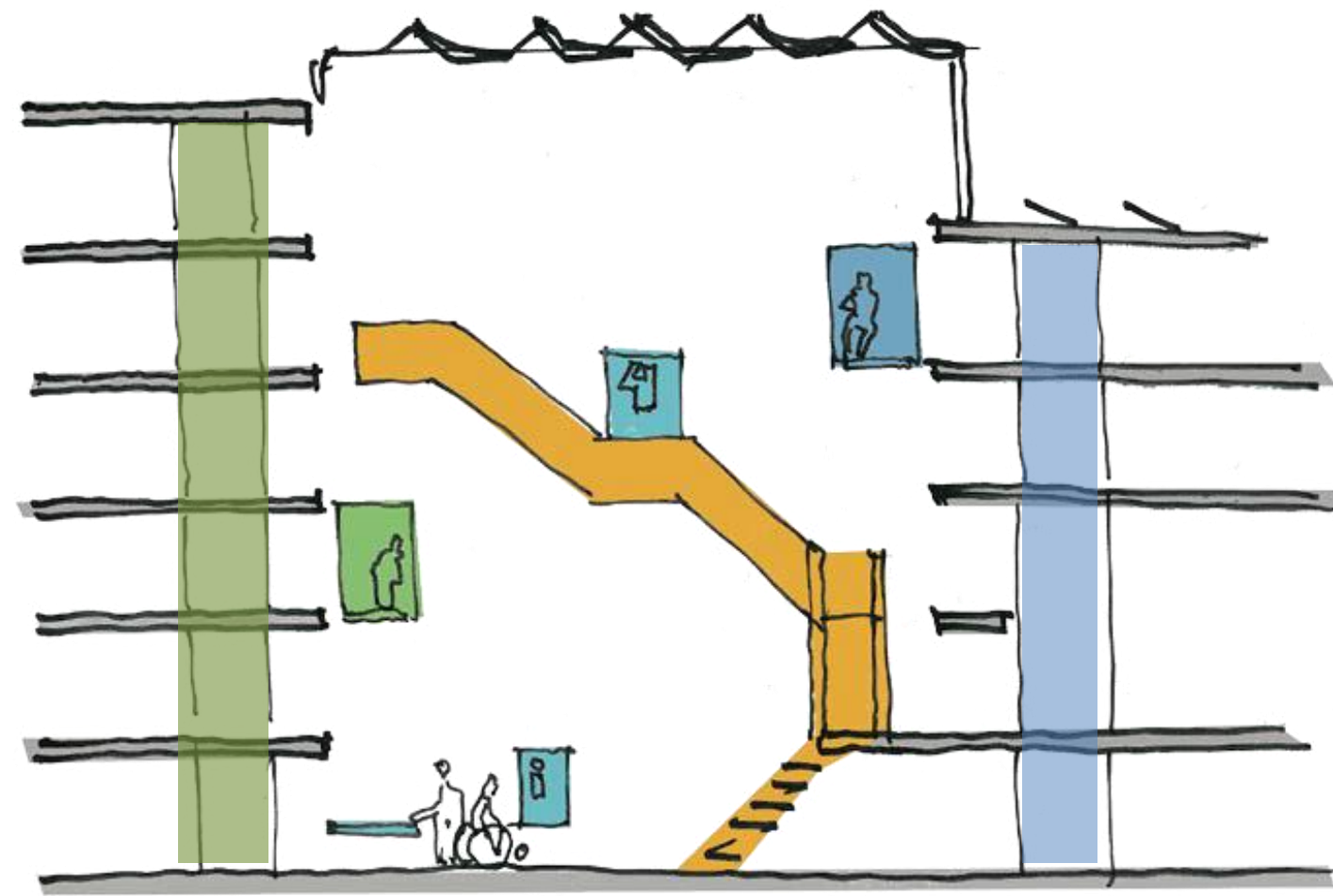

VERTIKALKOMMUNIKASJON OG
ORIENTERING

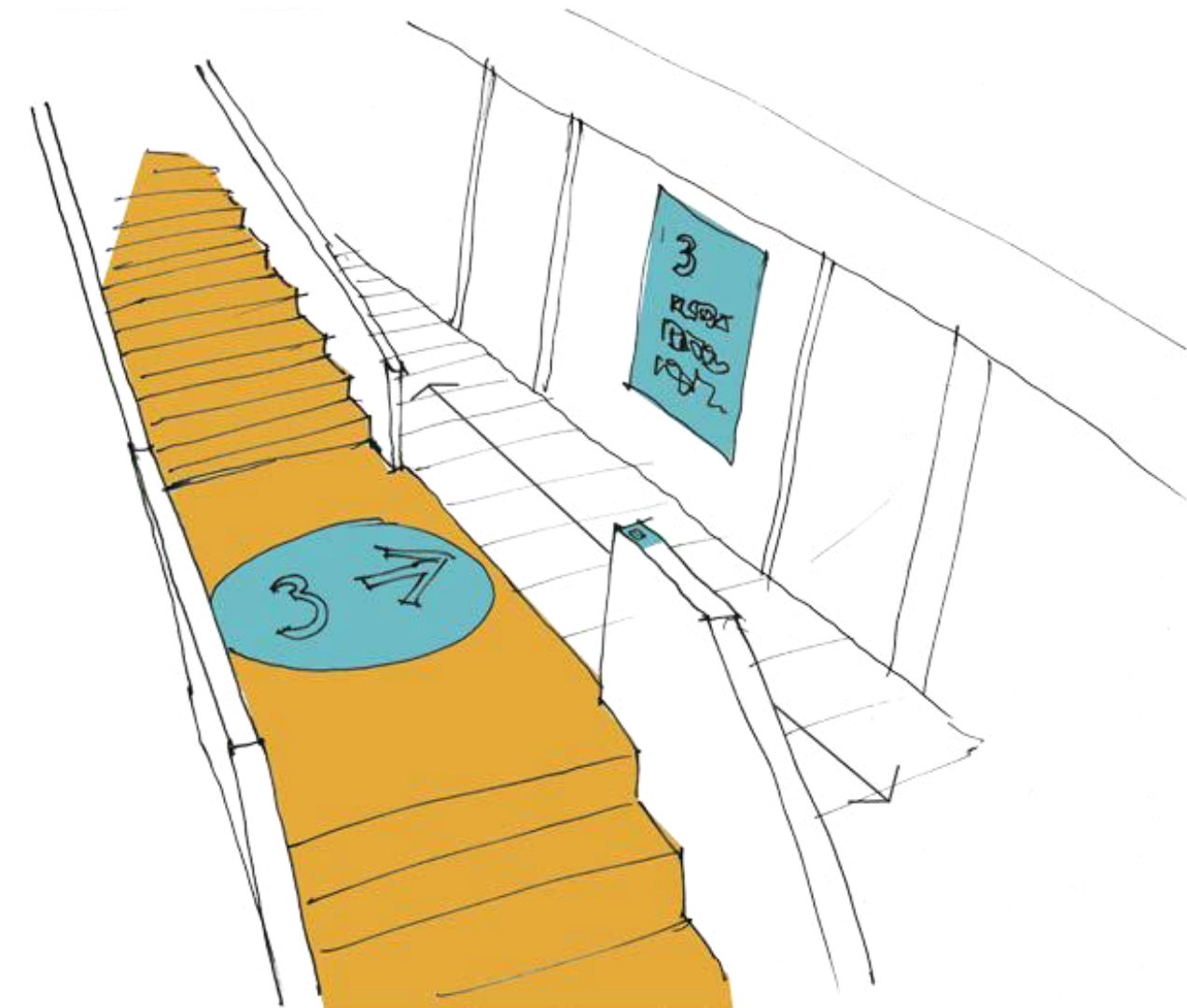

SKILTING OG INFOTAVLER PÅ ALLE
PLAN

Studenttorget

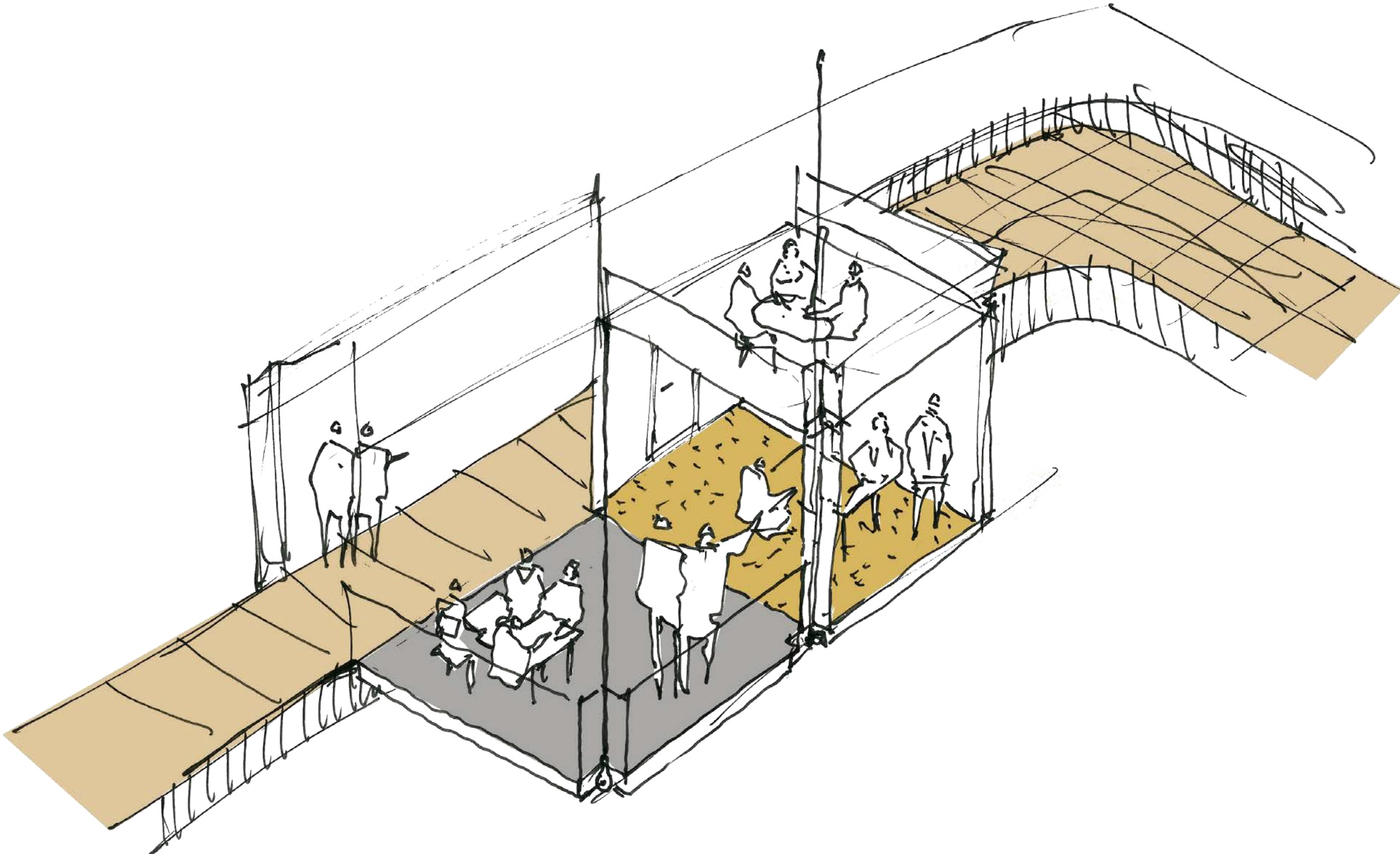

Sosiale soner, møterom, grupperom



Sosiale soner, møterom, grupperom

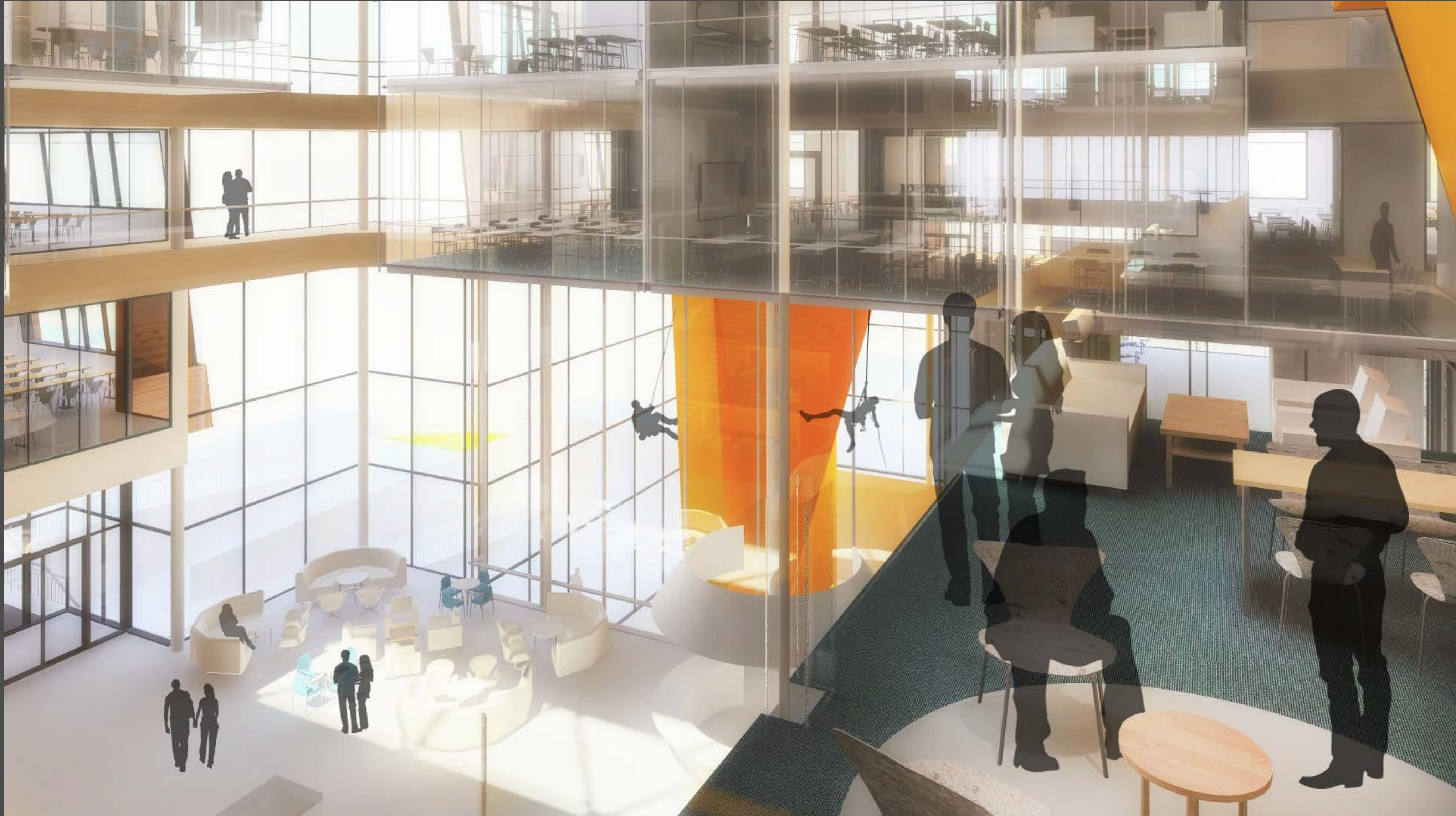

Snitt









