

The arrow indicate direction of benefit between courses



t % of students expressing "Good" or "Very Good" benefit



More than 75% of the students express "some", "Good" or "very good" benefit

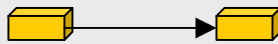

50-75% of the students express "some", "Good" or "very good" benefit

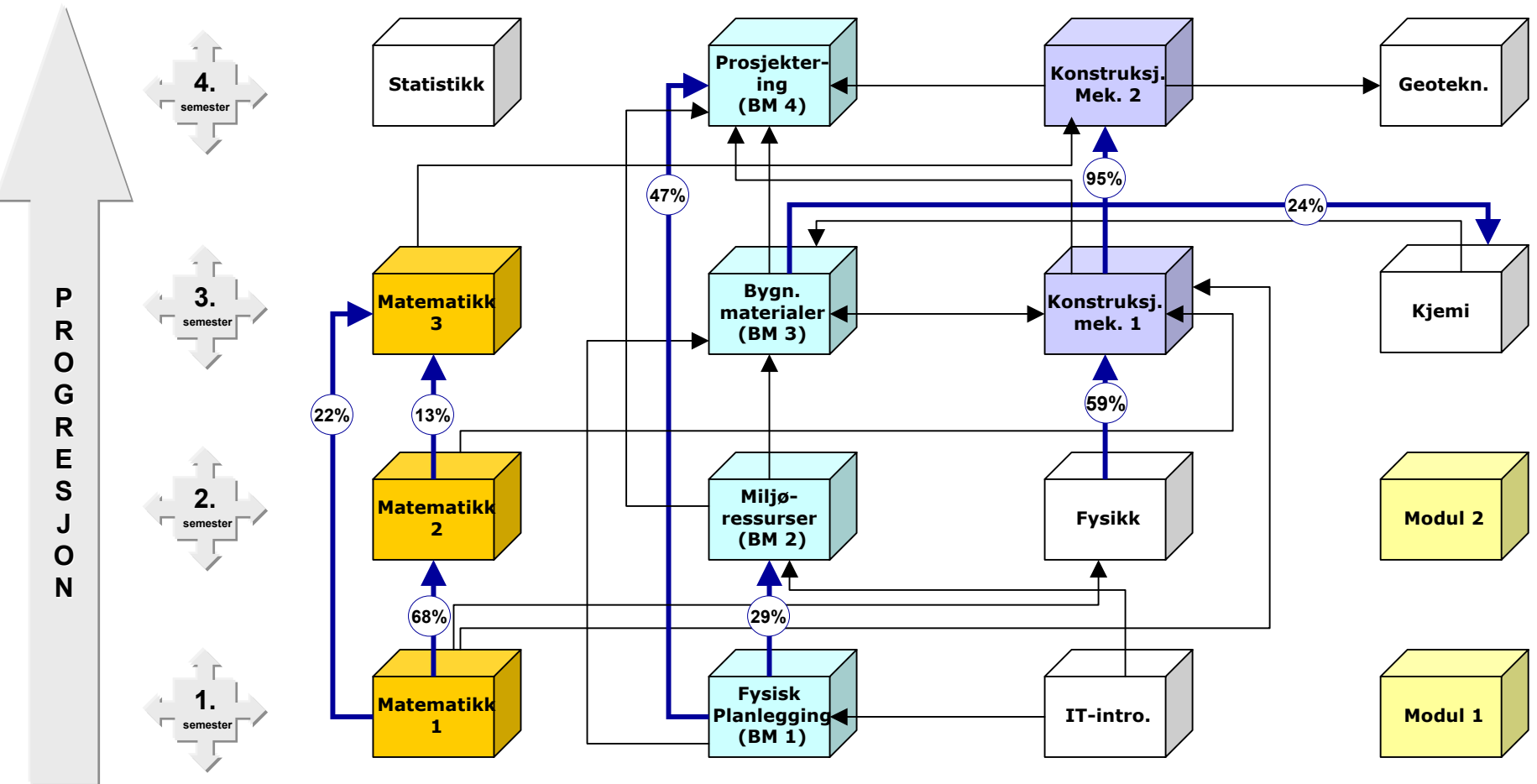

The arrow indicate direction of benefit between courses

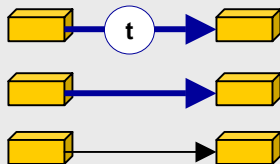

t % av studenter som oppgir "God" eller "Meget god" nytte

Over 75% av studentene har "noen", "God" eller "Meget god" nytte

50-75% av studentene har "noen", "God" eller "Meget god" nytte